

Product Line	CAKE DONUT DEPOSITOR	SPEC TYPEB/ 03-2013
Model	TYPE B	

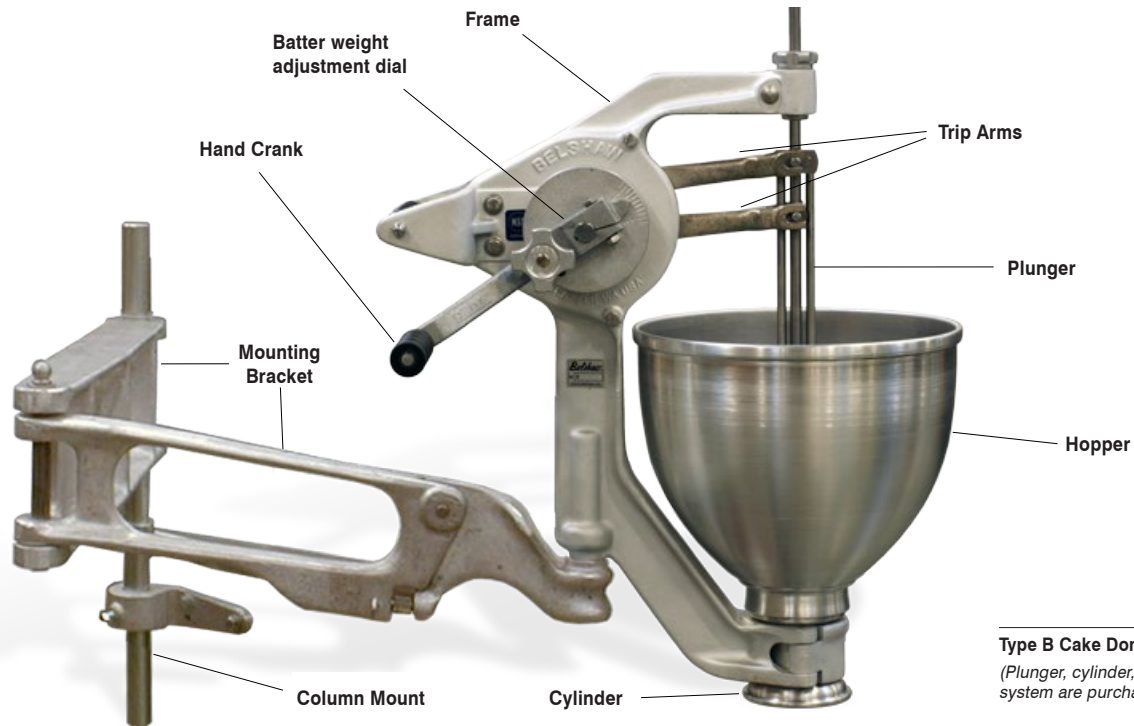

Type B Cake Donut Depositor
(Plunger, cylinder, and column mounting system are purchased separately)

TYPE B CAKE DONUT DEPOSITOR

Designed for quality cake donuts. Also makes excellent hushpuppies, loukoumades, falafel, ball-shaped fritters, and more, depending on the mix or recipe used.

Description

Belshaw depositors, the industry standard for many years, are legendary for their precision and smoothness of operation - even after years of use in harsh conditions. Each depositor is engineered of durable gears, cams and trip arms to produce identical volume and shape with every deposit.

An adjustment dial allows you to choose a generous range of batter weight for each deposit.

The Type B Depositor utilizes a hand crank to deposit at a rate up to 80 (or more) per minute. The internal workings of the Type B ensures a smooth turn of the crank handle and a well shaped deposit placed anywhere in the fryer. The service life of a Belshaw Type B is frequently measured in decades.

Plungers and Cylinders

Plungers are available for ring donuts, sticks, old fashions, crullers, krinkles and more. Any plunger used must be matched by a cylinder of the same size. This cylinder is inserted into the bottom of the hopper.

Standard features

(Apply to all models, unless otherwise specified)

- Aluminum alloy frame and arm assembly
- Hardened steel cams
- Bronze trip arms and bushings
- Aluminum hopper (Capacity 15 lbs/6.8 kg)
- Stainless steel and aluminum cylinder
- Deposit weight adjustment dial
- Crank handle
- Compatible with Belshaw Type B/Type F plungers and cylinders only

Options

- Frame only (no hopper)

Accessories

- Type B/F Column Mount (#0405)
- Wall Mount (#0406)
- Bracket Arm Height Adjuster (#0400)
- Plungers and cylinders. Because of the variety available, plungers and cylinders are not included as standard with Type B Depositor, but are purchased separately. See Page 3

90 Years of Quality Donut & Bakery Equipment

BELSHAW ADAMATIC BAKERY GROUP

814 44th St NW, Suite 103
Auburn, WA 98001 USA
PART OF ALI GROUP SPA

CONTACT

800.578.2547 (USA/CANADA)
(+1)206.322.5474 Worldwide
service@belshaw.com

WEB

www.belshaw-adamatic.com
www.belshaw.com
www.adamatic.com

SPEC
TYPEB/
03-2013

SHIPPING DIMENSIONS

- Shipping weight: 44 lbs (20 kg)
- Carton size: 18 "x 21" x 26" (46 x 54 x 66 cm)
- Freight class: 85
- Data is approximate for North America shipments

ELECTRICAL OPTIONS

- Rotary hand crank operation; no electrical power required

CERTIFICATIONS



Certified by NSF (G2)

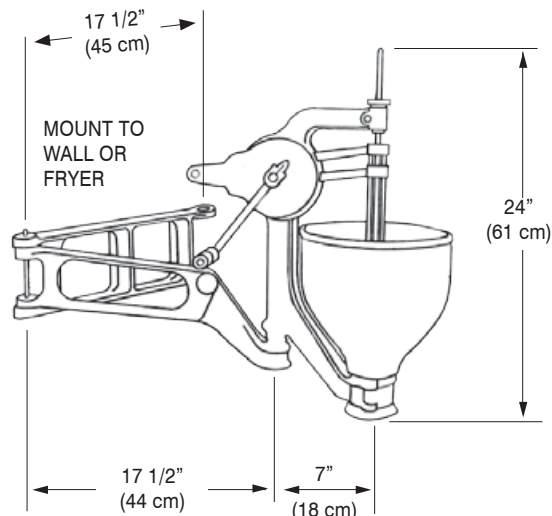

(NOTE: Diagram includes oplunger, cylinder and mounting bracket purchased separately)

MODEL SELECTION

Item Nbr.	Description Key	Options
B0001000	B-LB-W/O	Standard Type B depositor (plunger/cylinder not included)
0226CHS	B-LB-W/O-X	Standard Type B depositor frame only (no hopper)

Description Keys: **B=Type B** **LB=No mounting bracket** **W/O=No plunger/cylinder** **X=no hopper**

ACCESSORIES AND REPLACEMENT ITEMS

Item Nbr.	Description Key	Description
0405	COLUMN MOUNTING KIT	Column mount bracket kit, Type B
0406	WALL MT BRKT KIT	Wall mount bracket kit, Type B or F
0400	HEIGHT ADJ KIT	Bracket Arm Height Adjuster. Enables quick accurate adjustment to height of depositor. (For column mount only)
0290	HOPPER ASSY LG BORE	Hopper for Type B / Type F
0035SSAx[size]	CYL ASSY SS [size]	Cylinder for sizes up to 1-3/4" [insert size in inches]. Example: 0035SSAx1-3/4
0035SSBx[size]	CYL ASSY SS [size]	Cylinder for sizes from 1-7/8" or 2" [insert size in inches]. Example: 0035SSBx2

PLUNGERS AND CYLINDERS

Item Nbr.	Description Key	Description
For Plungers, see plungers section. Each plunger must match a cylinder of the same size. Different plungers may be used with just one cylinder, provided all are the same size. For instance, a 1-3/4" plunger can only be used with a 1-3/4" cylinder.		
0035SSAx[size]	CYL ASSY SS [size]	Cylinder for sizes up to 1-3/4" [insert size in inches]. Example: 0035SSAx1-3/4
0035SSBx[size]	CYL ASSY SS [size]	Cylinder for sizes 1-7/8" and larger [insert size in inches]. Example: 0035SSBx2

90 Years of Quality Donut & Bakery Equipment

BELSHAW ADAMATIC BAKERY GROUP

814 44th St NW, Suite 103
Auburn, WA 98001 USA
PART OF ALI GROUP SPA

CONTACT

800.578.2547 (USA/CANADA)
(+1)206.322.5474 Worldwide
service@belshaw.com

WEB

www.belshaw-adamatic.com
www.belshaw.com
www.adamatic.com

Item Number	Plunger Type	Photo	Donut type
7SSx[Size] [size]=1-1/2, 1-5/8, 1-3/4, 1-7/8, or 2 Example: 7SSx1-1/2 Size = diameter in inches	Plain Plunger Used for plain ring donuts (using standard cake donut mix) or for 'Old Fashion' donuts (using Old Fashion mix).		
7SC-SSx[Size] [size]=1-1/2, 1-5/8, 1-3/4, 1-7/8, or 2 Example: 7SC-SSx1-1/2 Size = diameter in inches	Star Plunger The Star plunger typically makes a ring donut with a more consistent, rounder hole than the plain plunger, with a star pattern around it.		
7B-1009x[Size] [size]=1-1/2, 1-5/8, 1-3/4, 1-7/8, or 2 Example: 7B-1009x1-7/8 Size = diameter in inches	French Cruller Plunger French Cake Plunger Use with French Cruller mix to make French Crullers. You can also make a 'French Cake' donut that is made with standard cake donut mix and looks similar, but without the eggy flavor and texture.		
7F-1004x[Size] [size]=1-1/2, 1-5/8, 1-3/4, 1-7/8, or 2 Example: 7B-1004x2 Size = diameter in inches	Krinkle Plunger This can be the most attractive of all cake donuts. Features eight distinctive ball shaped sections all joined together like a necklace. This plunger makes Asian 'Pon-de-Ring' donuts		
7G-1000-[Code] [code]=4 digit code for diameter, number of holes, and size of holes Ball plungers are made to order. Contact Belshaw when ordering Example: 7G-1000-082D	Ball Plunger (2,3,4 or 5 Holes) Produces ball shaped donuts or 'donut holes'. With a compatible mix recipe, can also make other products such as hushpuppies, loukoumades, falafel, fish balls, and more.		
7H-1000-[Code] (makes 1) 7H-1001-[Code] (makes 2) [code]=4 digit code for diameter, height and length of slot Example: 7H-1001-102AE Stick plungers are made to order. Contact Belshaw when ordering	Stick Plunger (1 or 2 Slots) Makes stick donuts with 1 or 2 slots. The size of the donut will depend on the size of the slot and on the dial setting of the depositor. (Setting 1 will be short, setting 2 or 3 will be longer)		
7-1025x1-3/4 [size]=1-3/4 only Size = diameter in inches	Dunkerette Plunger Plain plunger with a divider that forms 2 deposits, each approximately one half of a ring donut		
35SSAx[Size A] 35SSBx[Size B] [size A]=1-1/2, 1-5/8, or 1-3/4 [size B]=1-7/8 or 2 Example: 35SSAx1-3/4 Example: 35SSBx2 Size = diameter in inches	Cylinder for Type B/F Plunger size and cylinder size must always match. For example, a 1-3/4" plunger must always be used with a 1-3/4" cylinder. You can use any variety of plunger with a cylinder of the same size.		

90 Years of Quality Donut & Bakery Equipment

BELSHAW ADAMATIC BAKERY GROUP

814 44th St NW, Suite 103
Auburn, WA 98001 USA
PART OF ALI GROUP SPA

CONTACT

800.578.2547 (USA/CANADA)
(+1)206.322.5474 Worldwide
service@belshaw.com

WEB

www.belshaw-adamatic.com
www.belshaw.com
www.adamatic.com

Accessories for Type B and Type F Cake Donut Depositors



Column Mount Bracket Kit

The Column Mount supports both Type B or F cake donut depositors. The column is usually mounted on the left side of a Belshaw Adamatic fryer. For mounting on the right, the Bracket Plate can be moved from the left to the right side. Other fryers may accept the Column Mount if suitably strengthened (contact manufacturer) or if they will accept a Bracket Plate kit. Fryer must be bolted to the floor. The full extension of the column mount is 42"/105cm, from the column to the actual donut drop.

**Item Nbr #0405 (for Type B and Type F),
Item Nbr #P-1000 (Bracket Plate Kit, for non-Belshaw fryers—purchased separately)**

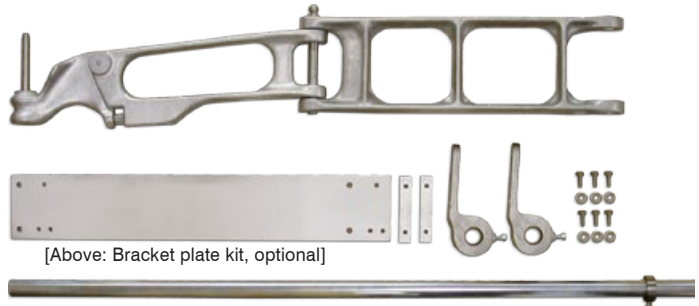

Wall Mount Bracket Kit

Supports Type B or F cake donut depositors, with precision screw for adjusting the angle of the depositor. Mounts to the wall behind or alongside fryer. Maximum extension 42"/105cm from wall to donut drop.

Item Nbr #0406



Bracket Arm Height Adjuster

The Bracket Arm Height Adjuster precisely adjusts the height of your Type B, F or N cake donut depositor. The large turn screw adjustment is both faster and more accurate than the standard Set Collar supplied with the standard mounting kits. Particularly useful when making more than one type of cake donut or other product. For column mount only.

Item Nbr #0400



Hopper

Replacement aluminum hopper for Type B and Type F. Capacity 15 lbs (6.8 kg). Accepts Belshaw Cylinders into bottom opening. (Supplied standard with standard Type B and Type F machines)

Item Nbr #0290



Plungers and Cylinders

A variety of plungers and cylinders are available for Type B and F depositors. (See Plungers / Cylinders page)



90 Years of Quality Donut & Bakery Equipment

BELSHAW ADAMATIC BAKERY GROUP

814 44th St NW, Suite 103
Auburn, WA 98001 USA
PART OF ALI GROUP SPA

CONTACT

800.578.2547 (USA/CANADA)
(+1)206.322.5474 Worldwide
service@belshaw.com

WEB

www.belshaw-adamatic.com
www.belshaw.com
www.adamatic.com