

Undercounter Freezers - Drawers

Undercounters
Super Deluxe Series

NEW Exceptional Quality 2 Years Parts and Labor Warranty



TUF-28SD-D2



TUF-48SD-D2



TUF-48SD-D4

FEATURES / BENEFITS

- EFFICIENT REFRIGERATION SYSTEM**
 Turbo Air's solid door freezers are designed with oversized and balanced (CFC Free R-404A) refrigeration systems. These include efficient evaporators and condensers for faster freezing and greater efficiency.
- STAINLESS STEEL CABINET CONSTRUCTION**
 The Turbo Air Super Deluxe model boasts a stainless steel interior and exterior (except the back). It guarantees the utmost in cleanliness and long product life. The Super Deluxe can add a touch of style to the most refined setting.
- HIGH-DENSITY POLYURETHANE INSULATION**
 The entire cabinet structure and solid doors are formed-in-place using high density, CFC free polyurethane insulation.
- DURABLE STAINLESS STEEL DRAWERS**
 Drawers are easy to clean and assemble.
- ERGONOMICALLY DESIGNED DOORS & DRAWERS**
 Customers' fatigue fades away with easy door grip and drawers that open effortlessly. These features along with self-closing doors make this the ultimate choice in customer convenience. ABS sheet door liners resist water condensation with thermal efficiency.
- MAGNETIC DOOR GASKETS**
 Magnetic door and drawer gaskets are of one piece construction, removable without tools for ease of cleaning and replacement.
- HOT GAS CONDENSATE SYSTEM**
 Through Turbo Air's creative innovation, the condensate system surfaces have been specially treated to resist corrosion. This not only increases efficiency without the risk refrigerant leakage from corrosion, but also prevents the overflow of condensate water.
- FREEZER HOLDS -5°F ~ -10°F FOR THE BEST IN FROZEN FOOD PRESERVATION**

Model	Swing Door	Drawers	CU./FT.	#of Shelves	HP	AMPS	Crated Weight	L D H
TUF-28SD-D2	-	2	7	-	1/3	53	169	27 1/2 x 30 x 30 5/8
TUF-48SD-D2	1	2	12	1	1/2	83	253	48 1/4 x 30 x 30 5/8
TUF-48SD-D4	-	4	12	-	1/2	83	260	48 1/4 x 30 x 30 5/8

* Height does not include 6-1/2" for caster height.

TUF MODELS SPECIFICATIONS

MODEL	TUF-28SD-D2	TUF-48SD-D2	TUF-48SD-D4
Exterior Dimension(LxDxH)	27 ¹ / ₂ x30x30 ⁵ / ₈	48 ¹ / ₄ x30x30 ⁵ / ₈	48 ¹ / ₄ x30x30 ⁵ / ₈
Cubic Feet	7	12	12
Compressor (HP)	1/3	1/2	1/2
# of Shelves	-	1ea	-
Net Weight	152 lbs	231 lbs	238 lbs
Voltage ⓘ NEMA-5-15P	ⓘ 115/60/1	ⓘ 115/60/1	ⓘ 115/60/1
Amp	5.3 A	8.3 A	8.3 A
Cord Length (ft.)	9	9	9
Plug-In	NEMA 5-15P	NEMA 5-15P	NEMA 5-15p

*Design and specifications subject to change without notice.

- **SELF-CONTAINED SYSTEM**
- **5" SWIVEL CASTERS**
- **2.5" CASTERS AVAILABLE FOR ALL MODELS (OPTIONAL)**
- **LEGS AVAILABLE FOR ALL MODELS (OPTIONAL)**
- **REMOTE CABINETS AND CONDENSING UNITS AVAILABLE FOR ALL MODELS.**

- **WARRANTY : 2 Years Labor and Parts Warranty
Additional 3 Years Warranty on Compressor**

(unit : inch)

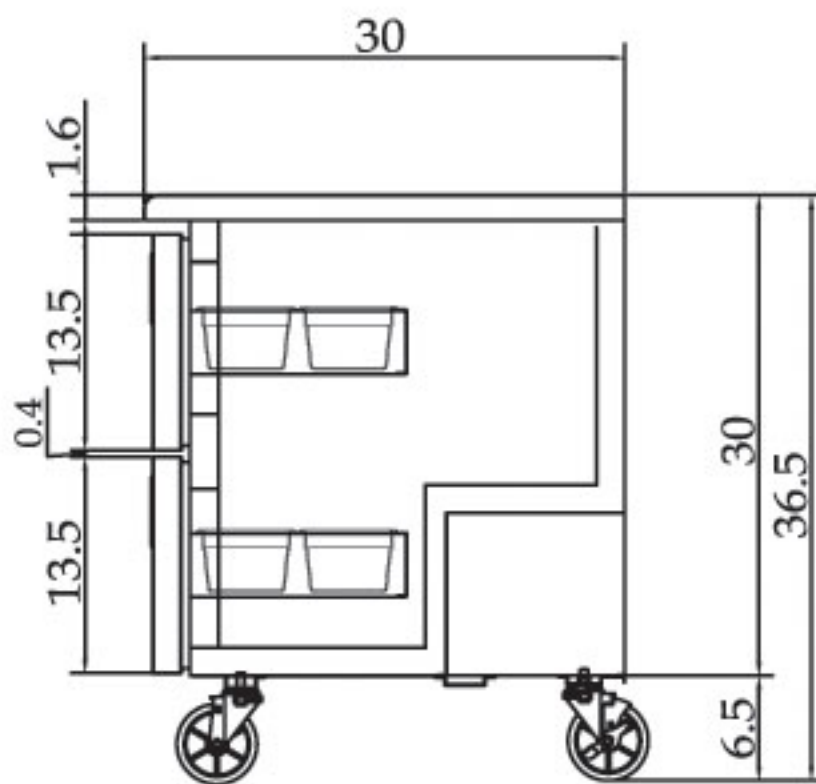

SIDE VIEW

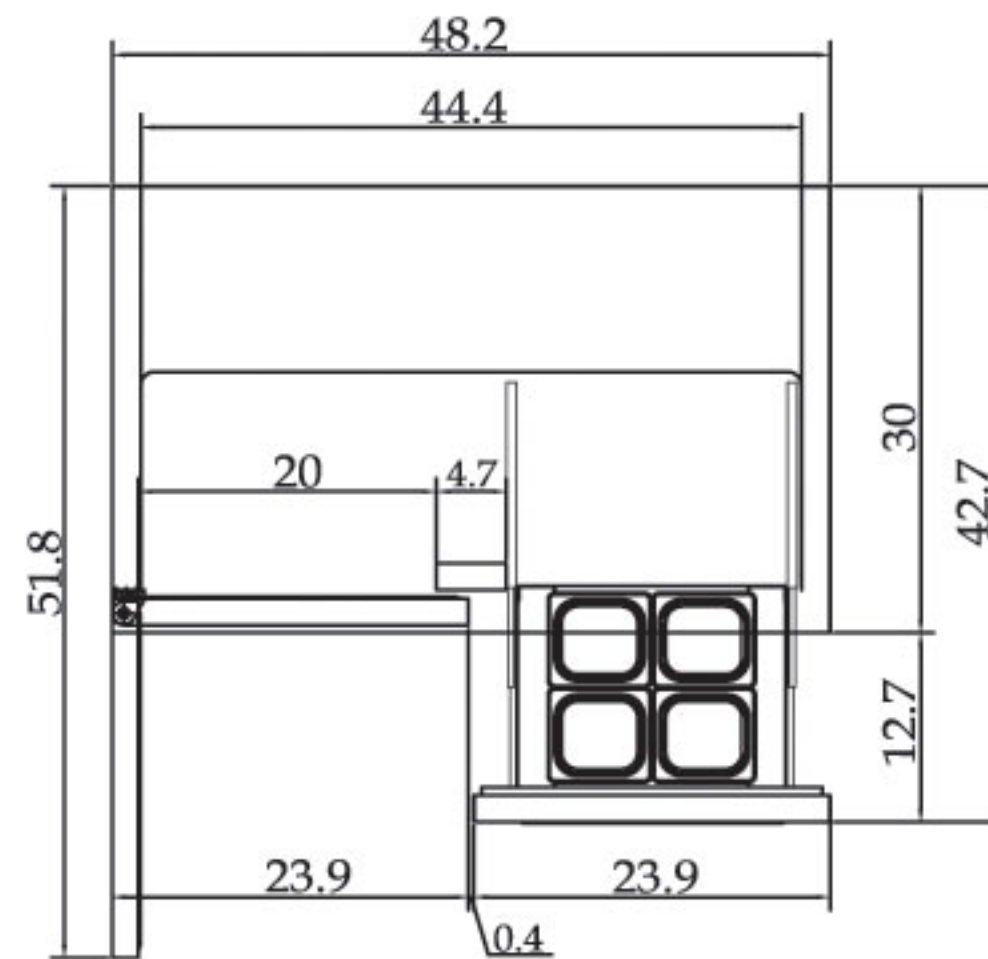

TUF-48SD-D2 PLAN VIEW

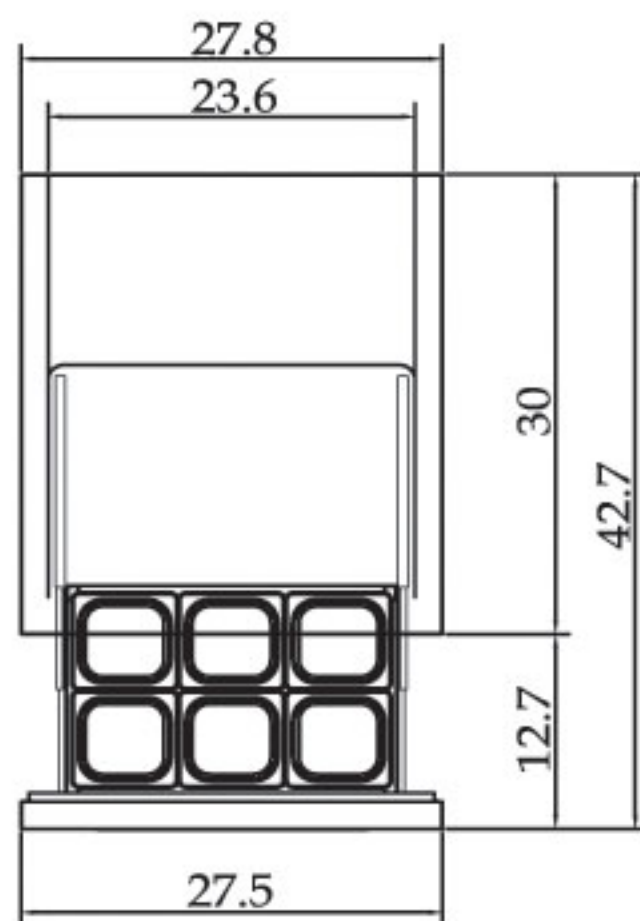

TUF-28SD-D2 PLAN VIEW

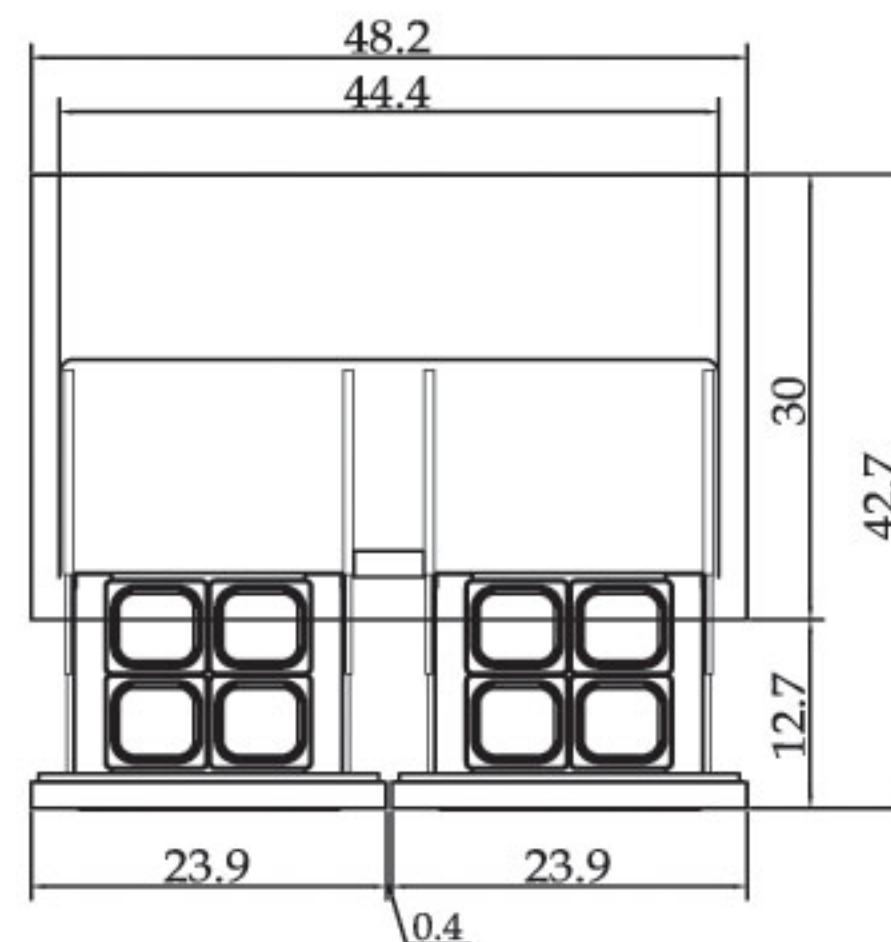

TUF-48SD-D4 PLAN VIEW